

Product catalogue 2018

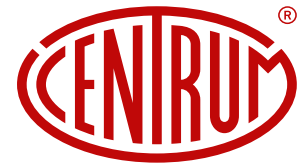

Business to Business. Since 1985

# KITCHEN QUARTZ SINKS





Business to Business. Since 1985

# EVERYDAY WITH YOU

Meet our modern and functional solutions for your kitchen.

Among the most important advantages of granite conglomerate kitchen sinks are:

- wide range of applications and kitchen arrangements
- resistance to UV rays and temperature changes
- resistance to chemicals and staining products
- resistance to impact and scratches
- indifference to odours
- simple installation
- easy cleaning
- antimicrobial properties
- high aesthetics

# WELCOME TO CENTRUM COMPANY

Renowned producer of granite kitchen sinks

Our mission is to consolidate our market position in designing, manufacturing and delivering goods from plastics and to become a preferred supplier. We want to achieve this goal by ensuring that our customers receive reliable, high quality goods and by basing our production on experience, continuous innovations and cooperation of exceptional value.

- internal production of models and forms
- fully automated raw material proportioning from producer's/collective containers
- goods identification thanks to RFID system
- detailed quality control
- 16 production lines
- 20 000 m<sup>2</sup> of production floor area
- approximately 8 000 m<sup>2</sup> of warehouse space
- over 30 years of business experience



We are changing for you. We want to meet your requirements by embracing new technological solutions and bringing new production lines to life.

# B2B PRODUCT DESIGN CENTER

A wide range of possibilities to configure the trade offer

The Centrum company has been dealing with kitchen sink production for many years. Our commitment to work, care for customer expectations, full professionalism and many years of experience are the factors which allow us to offer the products which are the response to the need of having practical and effective kitchen equipment.

- a wide range of models and forms to choose
- universal and elegant palette of standard colours
- convenient and reliable cooperation
- 2-year warranty

# A WIDE RANGE OF MODELS

## Always in style

Our kitchen sinks are created with great care for the tiniest details. We care not only for the selection of the best materials but also for interesting design and colours. In our current offer you will find one- and two compartment sinks with or without a drainboard as well as undercounter models.

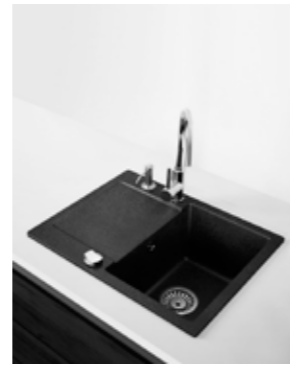

A multitude of models provides flexibility in designing, for instance in two-sided sinks the drainboards can be mounted on the right or on the left.

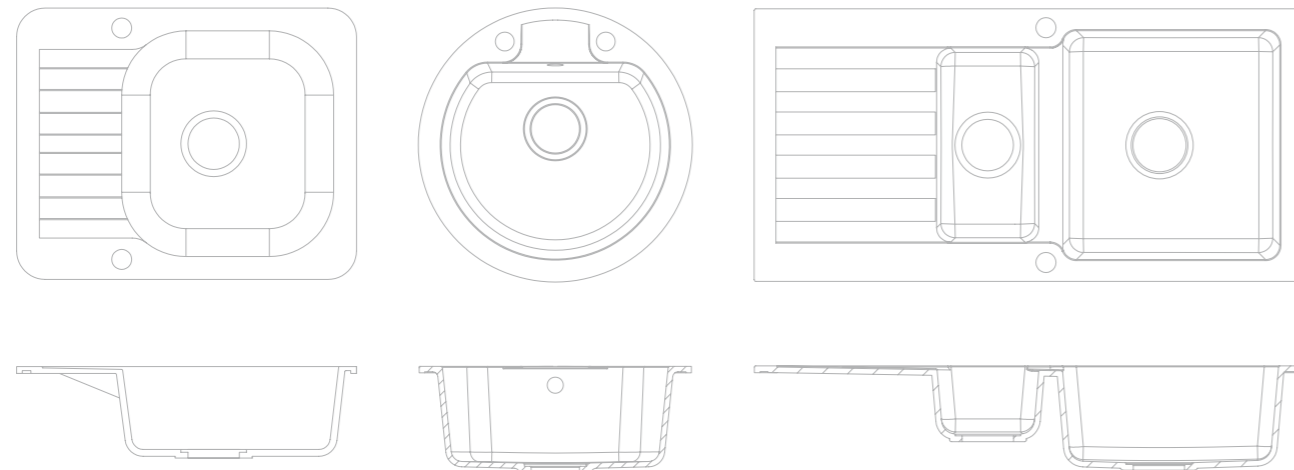

Variety of models in 8 colours enables to create interesting and highly diversified trade offer. Available products are made of high quality materials and meet the demands of European quality standards. All models are under 2-year warranty.



Thanks to small dimensions, undercounter sinks are ideal for smaller kitchens and kitchenettes without taking too much space. Thanks to the use of high quality materials our sinks stand out from other granite sinks available on the market.

# UNIVERSAL COLOUR PALETTE

## Timeless colours

We offer kitchen sinks in very light colours, starting with shades of cream, beige, grey and finishing with deep graphite and black. Our proposals perfectly match different styles of interiors. They fit beautifully into classic spaces and blend in perfectly with modern ones.

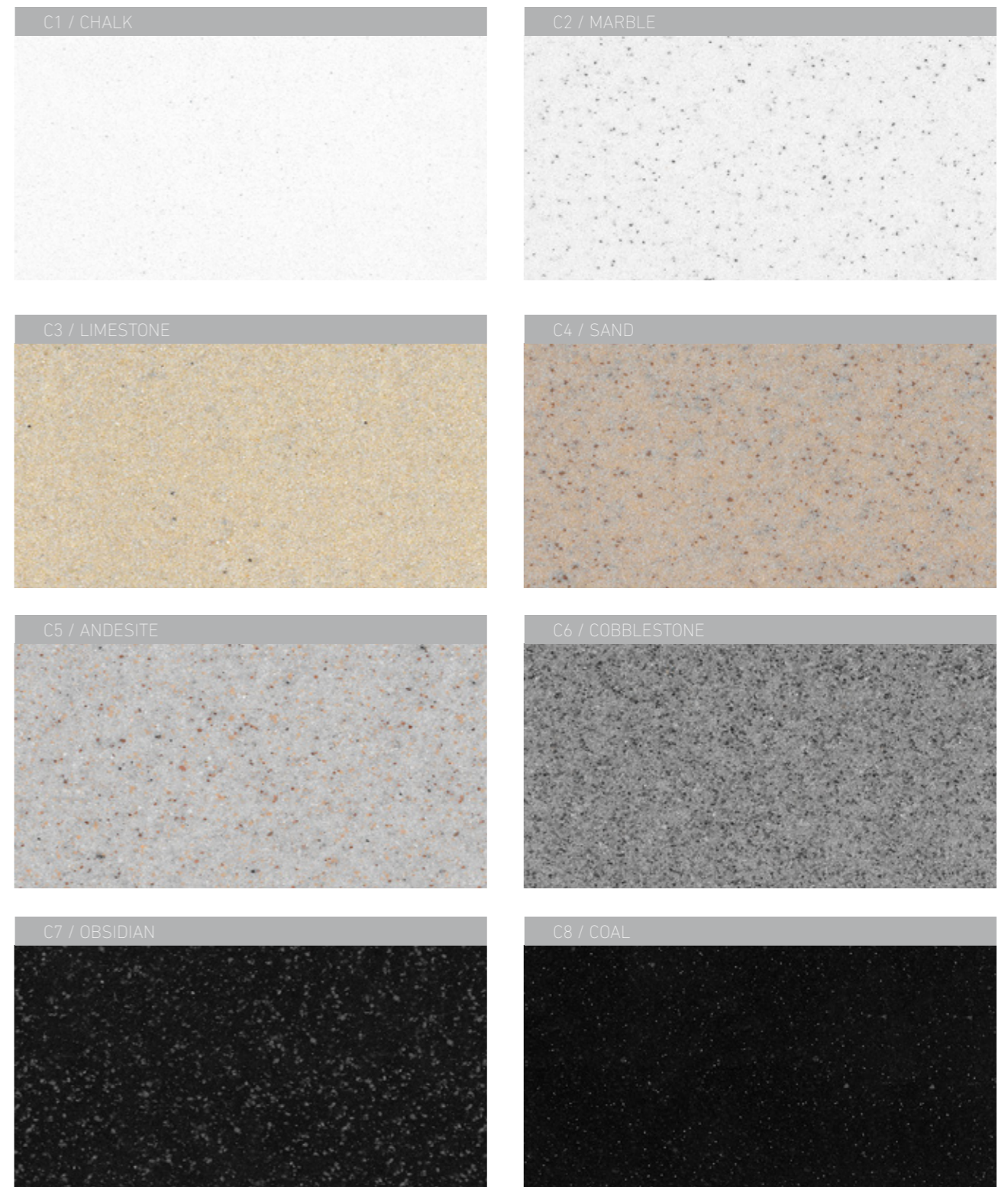



# SAFE USE EVERY DAY

Effective antibacterial protection is the safety of your kitchen every day.

## REALLY SAFE KITCHEN IN YOUR HOME

### NANO SILVER TECHNOLOGY - innovative protective power of sterile molecules

We recommend choosing the extra NANO SILVER TECHNOLOGY antimicrobial coating which fights bacteria and prevents the growth of bacteria and fungi on the sink surface. During the production, the mixture of mineral fillers is enriched with colloidal solution of silver. Nanoparticles of this metal are present on the whole sink surface and always activate during using. Colloidal silver (pure metallic silver suspended in water) is non-toxic, colourless and odourless.

The certified nano silver coating never loses its properties and cannot be wiped during use.

Innovative and specialized products for your kitchen – kitchen sinks with new properties – allow us to direct the offer to clients with full awareness of the need of microbiological protection.



The use of antimicrobial coating is a guarantee of safety for your loved ones during everyday kitchen activity.

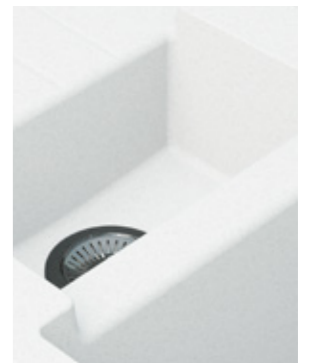

Granite conglomerate has a uniform structure and exceptional durability. It can be additionally enriched with approved antimicrobial nano silver coating which destroys fungi, mould and most bacteria and has also got a disinfecting effect.

# 1 COMPARTMENT SINKS

## Compact ergonomics

One compartment sinks are perfect for modern kitchens. Smooth edges without additional embellishments emphasise the character of a minimalist style kitchen. Due to small dimension they are ideal for smaller kitchens and kitchenettes without taking up too much space on a countertop.

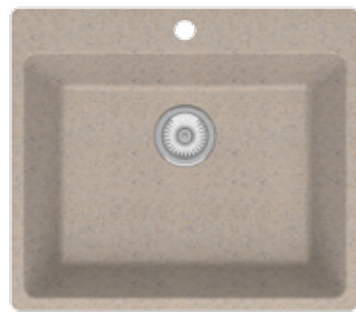

### CINQUE 1

1 compartment countertop sink  
Dimensions: 575 x 500

- adapted for countertop installation
- available in 8 colours
- high quality siphon
- slightly rounded edge finish
- simple minimalist style
- deep compartment

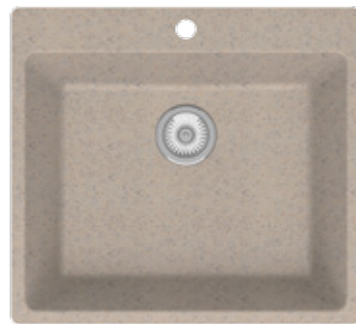

### CINQUE 2

1 compartment countertop sink  
Dimensions: 585 x 530

- adapted for countertop installation
- available in 8 colours
- high quality siphon
- slightly rounded edge finish
- simple minimalist style
- deep compartment

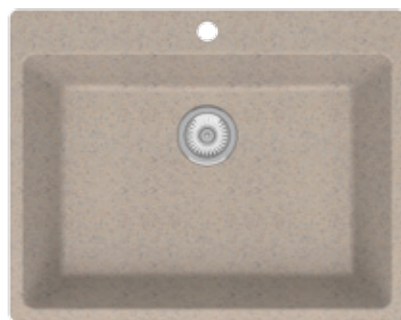

### CINQUE 3

1 compartment countertop sink  
Dimensions: 670 x 530

- adapted for countertop installation
- available in 8 colours
- high quality siphon
- slightly rounded edge finish
- simple minimalist style
- deep compartment

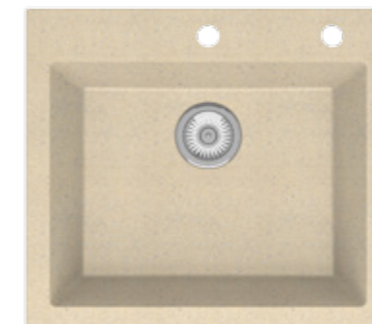

### FINO

1 compartment countertop sink  
Dimensions: 565 x 500

- adapted for countertop installation
- available in 8 colours
- high quality siphon with safe overflow
- simple and geometric edges

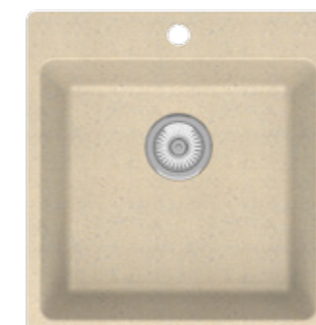

### NOTERRI

1 compartment countertop sink  
Dimensions: 470 x 500

- adapted for countertop installation
- available in 8 colours
- high quality siphon
- slightly rounded edge finish
- small sizes dedicated to narrow kitchen cupboards



All 1 compartment sinks are available in 8 universal colours from the standard palette.

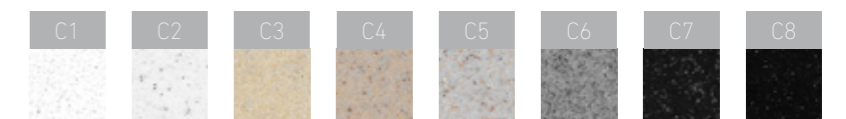

# 1 COMPARTMENT KITCHEN SINKS + DRAINBOARD

## Maximum comfort of use

Our offer provides the models of one compartment kitchen sinks with a practical drainboard. It is a perfect solution for people having dishwashers or eating out. They do not take too much space therefore they are perfect for kitchenettes and small kitchens.



A larger drainboard surface will certainly facilitate kitchen work and dishwashing. Due to ergonomic design of our sinks with drainboards this activity will be much easier and pleasant.

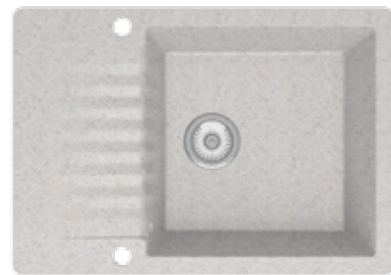

### GROTICELLE

1 compartment countertop sink with drainboard  
Dimensions: 715 x 500

- adapted for countertop installation
- available in 8 colours
- high quality siphon with safe overflow
- small practical drainboard

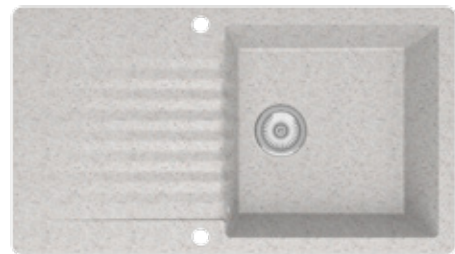
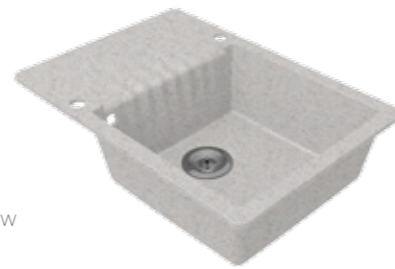

### FUILI

1 compartment countertop sink with drainboard  
Dimensions: 895 x 500

- adapted for countertop installation
- available in 8 colours
- high quality siphon with safe overflow
- large practical drainboard

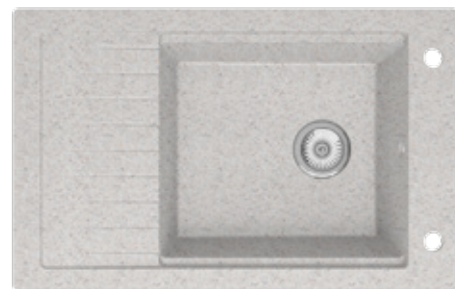
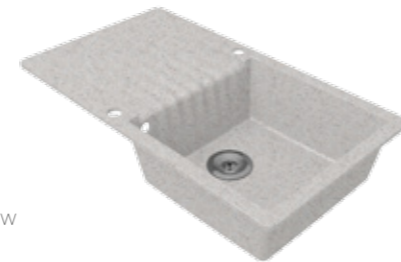

### BELLO

1 compartment countertop sink with drainboard  
Dimensions: 800 x 505

- adapted for countertop installation
- available in 8 colours
- high quality siphon with safe overflow
- small practical drainboard

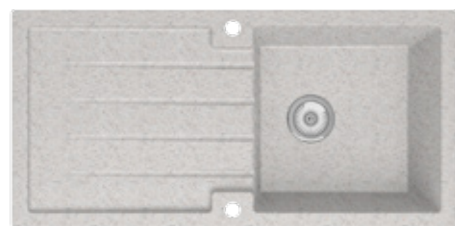

### BOSA

1 compartment countertop sink with drainboard  
Dimensions: 980 x 480

- adapted for countertop installation
- available in 8 colours
- high quality siphon with safe overflow
- extra large practical drainboard



### VELLO

1 compartment countertop sink with drainboard  
Dimensions: 780 x 500

- adapted for countertop installation
- available in 8 colours
- high quality siphon with safe overflow
- minimalist and simple form
- small smooth drainboard with a rim

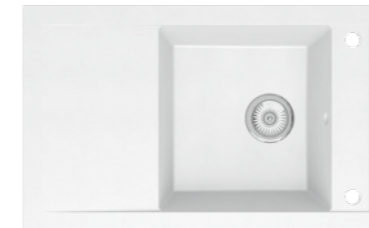

### POLLICA

1 compartment countertop sink with drainboard  
Dimensions: 780 x 480

- adapted for countertop installation
- available in 8 colours
- high quality siphon with safe overflow
- minimalist and simple form
- medium smooth drainboard



### SPEZIA

1 compartment countertop sink with drainboard  
Dimensions: 970 x 500

- adapted for countertop installation
- available in 8 colours
- high quality siphon with safe overflow
- minimalist and simple form
- smooth spacious drainboard with a rim



### ALBRO

1 compartment countertop sink with drainboard  
Dimensions: 1140 x 575

- adapted for countertop installation
- available in 8 colours
- high quality siphon with safe overflow
- characteristic arch finish
- smooth spacious drainboard



# 1 COMPARTMENT KITCHEN SINKS + DRAINBOARD

## Quality is the key

Our kitchen sinks are distinguished not only by perfect aesthetics but also by durability and functionality. As producers, we care about the selection of good quality materials having in mind high aesthetics of products. We use excellent quality resins and 80% granite aggregates providing the highest quality of our sinks.

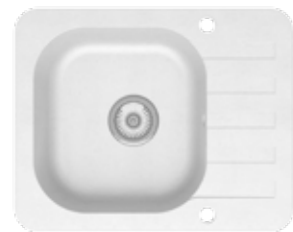

### ERCOLE

1 compartment countertop sink with drainboard  
Dimensions: 595 x 475

- adapted for countertop installation
- available in 8 colours
- high quality siphon with safe overflow
- clearly rounded corners
- small grooved drainboard

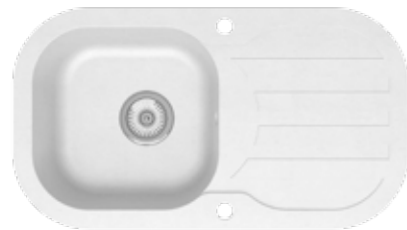

### LIDO

1 compartment countertop sink with drainboard  
Dimensions: 780 x 435

- adapted for countertop installation
- available in 8 colours
- high quality siphon with safe overflow
- clearly rounded corners
- large grooved drainboard



## Pure pleasure of use

Keeping a granite sink ideally clean is very simple and does not require many care treatments. High quality granite provides resistance to scratches, impacts and rapid changes of temperature.

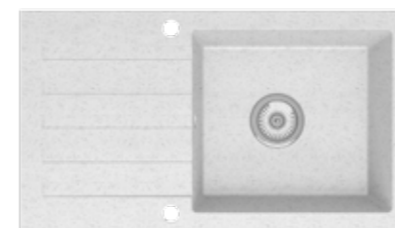

### AROLA

1 compartment countertop sink with drainboard  
Dimensions: 780 x 440

- adapted for countertop installation
- available in 8 colours
- high quality siphon with safe overflow
- universal and simple form
- standard grooved drainboard

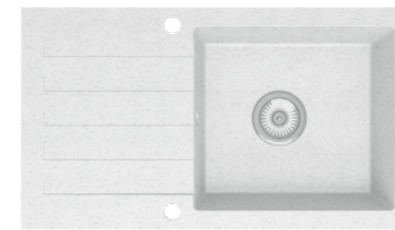
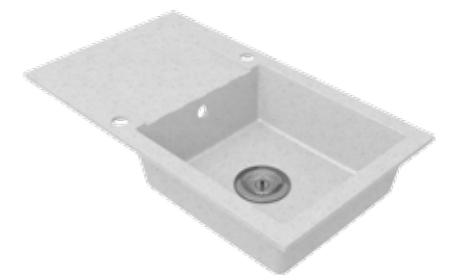

### URBINO

1 compartment countertop sink with drainboard  
Dimensions: 780 x 480

- adapted for countertop installation
- available in 8 colours
- high quality siphon with safe overflow
- universal and simple form
- standard grooved drainboard

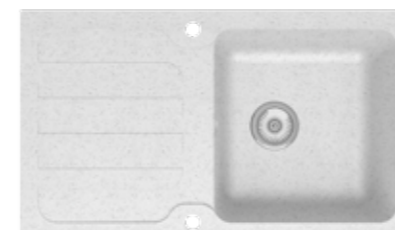

### MONTE

1 compartment countertop sink with drainboard  
Dimensions: 860 x 500

- adapted for countertop installation
- available in 8 colours
- high quality siphon with safe overflow
- slightly rounded edge finish
- standard grooved drainboard

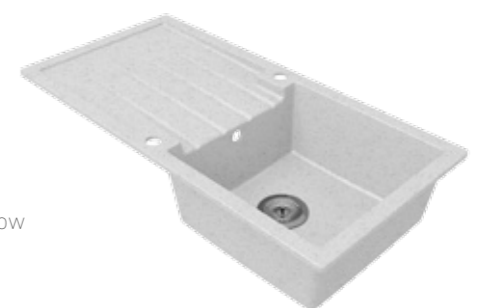

All 1 compartment sinks with a drainboard are available in 8 universal colours from the standard palette.

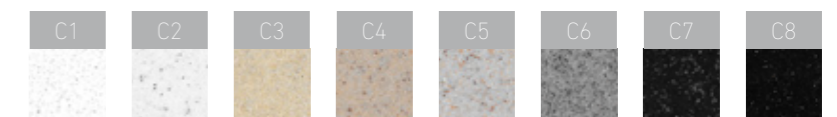

# 1.5 COMPARTMENT KITCHEN SINKS + DRAINBOARD

Everything within reach

One and a half compartment kitchen sinks have simple but functional structure. They are ideal for traditional and modern kitchens. They can be used as a standalone equipment in a washing zone or can be a supplement for a dishwasher. They stand out with their elegant timeless design.

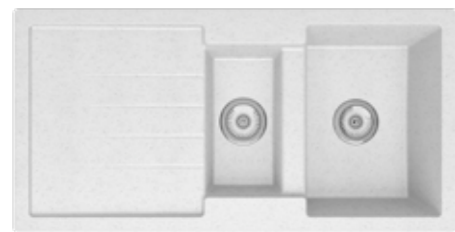

## ROSETO

1.5 compartment countertop sink with drainboard  
Dimensions: 1017 x 512

- adapted for countertop installation
- available in 8 colours
- high quality siphon with safe overflow
- 2 different sizes compartments
- spacious drainboard with gentle ornament finished with practical rim

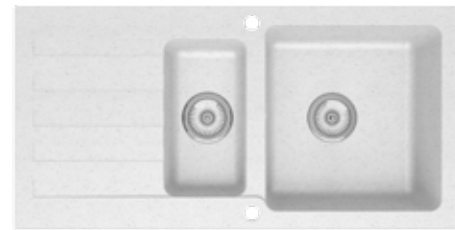

## ATRANI

1.5 compartment countertop sink with drainboard  
Dimensions: 960 x 480

- adapted for countertop installation
- available in 8 colours
- high quality siphon with safe overflow
- 2 different sizes compartments
- standard drainboard with gentle ornament

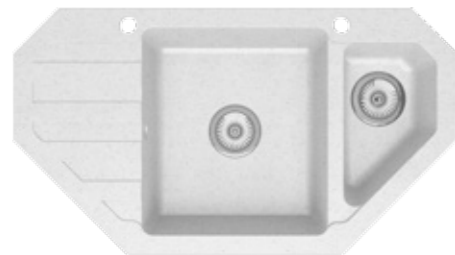

## OTRANTO

1.5 compartment countertop sink with drainboard  
Dimensions: 900 x 500

- adapted for countertop installation
- available in 8 colours
- high quality siphon with safe overflow
- 2 different sizes compartments
- small practical trapezoidal drainboard
- possibility of installation in the corner of construction

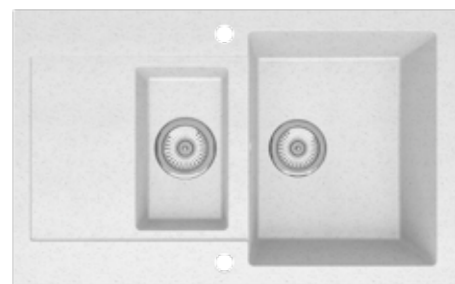

## RINELLA

1.5 compartment countertop sink with drainboard  
Dimensions: 800 x 500

- adapted for countertop installation
- available in 8 colours
- high quality siphon with safe overflow
- 2 different sizes compartments
- simple minimalist style
- small practical drainboard



# 2 COMPARTMENT KITCHEN SINKS

More possibilities

Two compartment kitchen sinks are particularly recommended for larger kitchens. Two symmetrical large compartments are perfect for preparing meals. Sinks have a 35 mm hole allowing the installation of any type of a battery.

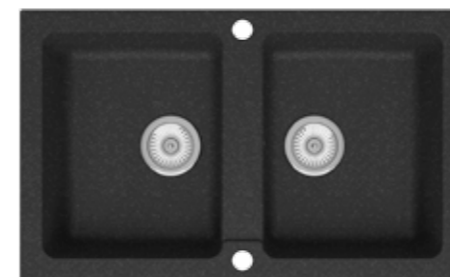
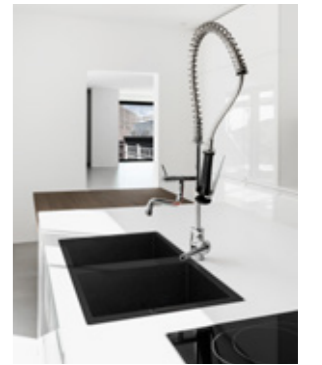

## TREZZA

2 compartment countertop sink  
Dimensions: 870 x 500

- adapted for countertop installation
- available in 8 colours
- high quality siphon with safe overflow
- universal and simple form
- 2 large compartments

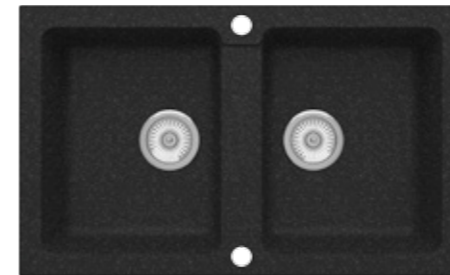

## LONGA

2 compartment countertop sink  
Dimensions: 780 x 475

- adapted for countertop installation
- available in 8 colours
- high quality siphon with safe overflow
- universal and simple form
- 2 large compartments



All 1.5 compartment sinks with a drainboard and 2 compartment sinks are available in 8 universal colours from the standard palette.

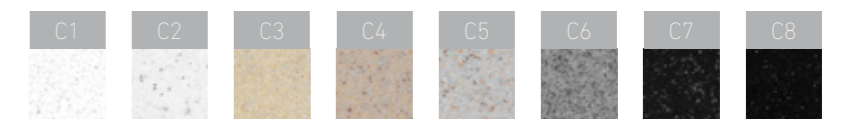



# ROUND KITCHEN SINKS

## Functionality around the clock

Round sinks are a perfect solution for small kitchens or not big kitchenettes and kitchens equipped with a dishwasher. Original surface of a sink in subdued colours and clearly marked edges make the whole look very elegant.

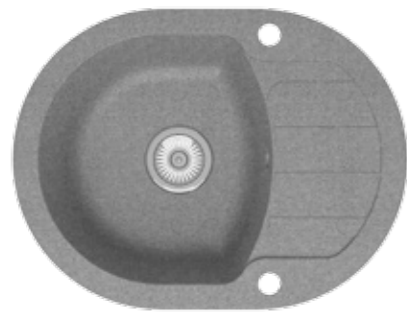

### ISOLA

1 compartment round sink with drainboard  
Dimensions: 610 x 465

- adapted for countertop installation
- available in 8 colours
- high quality siphon with safe overflow
- characteristic oval shape
- small practical grooved drainboard

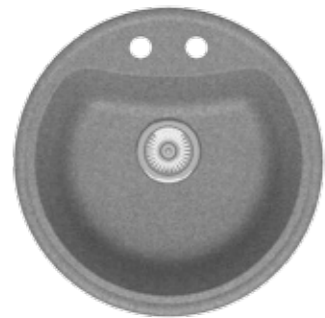

### LINGANO

1 compartment round sink  
Dimensions: 500 x 500

- adapted for countertop installation
- available in 8 colours
- high quality siphon with safe overflow
- round shape
- arch and smooth edge finish

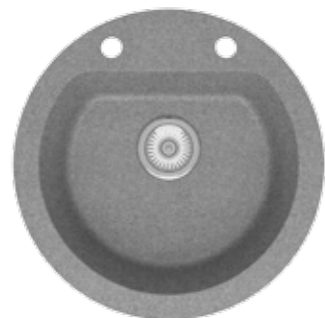

### CASTEL

1 compartment round sink  
Dimensions: 510 x 510

- adapted for countertop installation
- available in 8 colours
- high quality siphon with safe overflow
- round shape
- simple and smooth edge finish



In a small rarely used kitchen it is enough to install a granite one compartment sink in a round shape for instance. It has a small size and its functionality comes down to rinsing two glasses and a few tea spoons a day. It will be a perfect complement to modern design and will not cause any trouble with exploitation and maintenance as well.

# UNDERCOUNTER KITCHEN SINKS

## Discreet installation

In our offer you will find rectangular suspended sinks. We offer one- and one and a half compartment models. They are designed for all types of kitchen counters and are discretely mounted under the counter.



### PROCIDA

1.5 compartment undercounter sink  
Dimensions: 558 x 460

- adapted for undercounter installation
- available in 8 colours
- high quality siphon with safe overflow
- slightly rounded edge finish
- ergonomic division into smaller and larger compartment

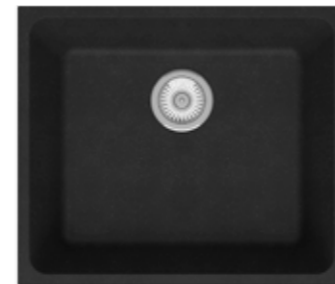

### NEMI

1 compartment undercounter sink  
Dimensions: 540 x 460

- adapted for undercounter installation
- available in 8 colours
- high quality siphon with safe overflow
- slightly rounded edge finish
- optimal usable usage



### TERRE

1 compartment undercounter sink  
Dimensions: 540 x 440

- adapted for undercounter installation
- available in 8 colours
- high quality siphon with safe overflow
- slightly rounded edge finish
- optimal usable usage



### MINTUMO

1 compartment undercounter sink  
Dimensions: 367 x 460

- adapted for undercounter installation
- available in 8 colours
- high quality siphon with safe overflow
- small usable size enabling installation in a 45 cm wide cabinet



# TECHNICAL DATA

## Detailed sizes and technical drawings

Detailed technical drawings of our kitchen sinks will allow you to familiarize with all parameters. Under the drawings there are all dimensions and technical data of each model.

**CINQUE 1**  
Dimensions: 575 x 500

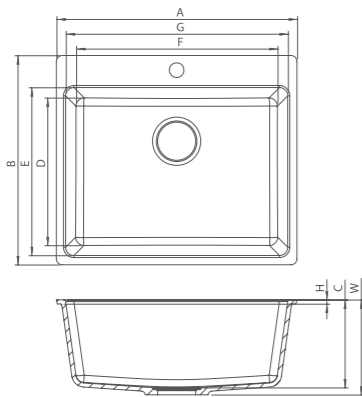

A	B	C	D	E	F	G	H	W
575	500	210	353	401	481	531	10	227

**CINQUE 2**  
Dimensions: 585 x 530

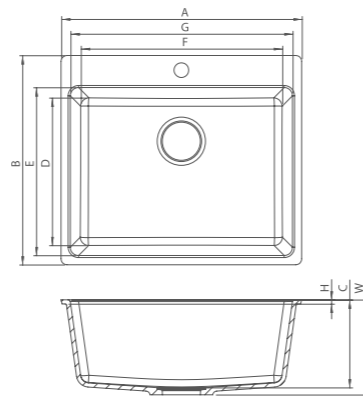

A	B	C	D	E	F	G	H	W
585	530	210	353	401	481	531	10	227

**CINQUE 3**  
Dimensions: 670 x 530

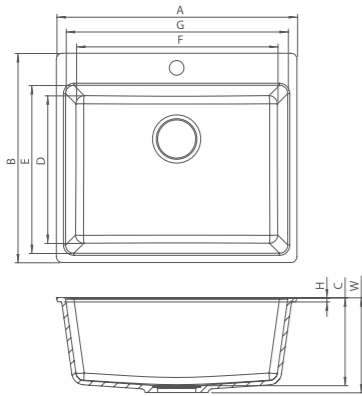

A	B	C	D	E	F	G	H	W
670	530	210	353	401	481	531	10	227

**FINO**  
Dimensions: 565 x 500

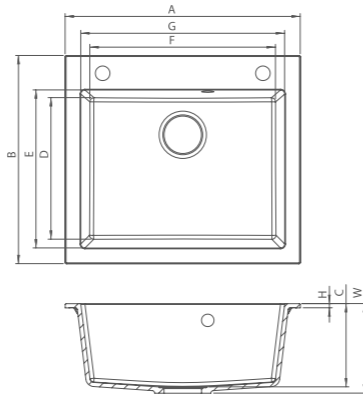

A	B	C	D	E	F	G	H	W
565	500	200	340	380	446	490	10	215

**NOTERRI**  
Dimensions: 470 x 500

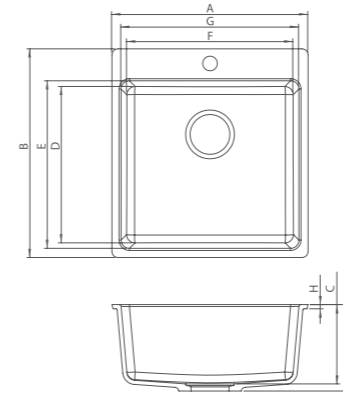

A	B	C	D	E	F	G	H	W
470	500	190	375	402	399	426	10	207

**GROTICELLE**  
Dimensions: 715 x 500

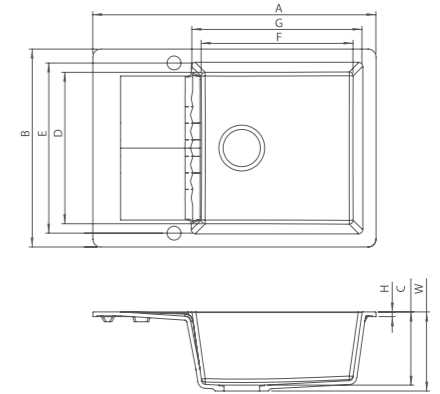

A	B	C	D	E	F	G	H	W
715	500	185	383	430	383	430	12	200

**FULI**  
Dimensions: 895 x 500

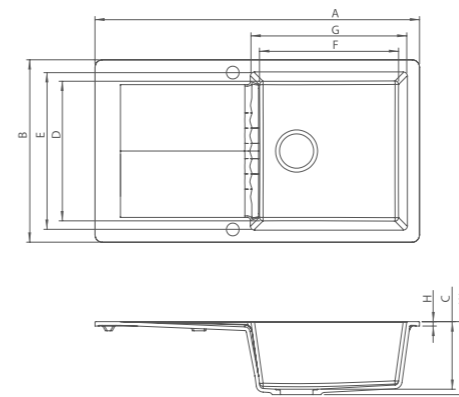

A	B	C	D	E	F	G	H	W
895	500	185	383	430	383	430	12	200

**BELLO**  
Dimensions: 800 x 505

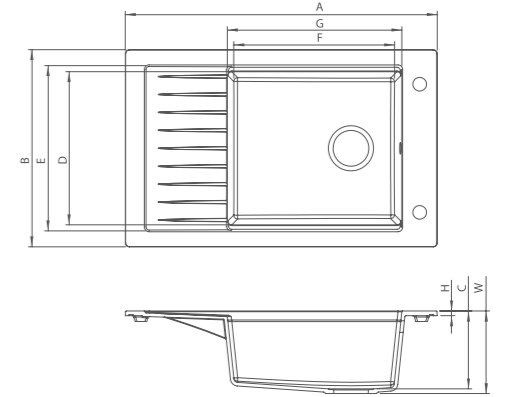

A	B	C	D	E	F	G	H	W
800	505	200	393	425	413	448	12	212

**BOSA**  
Dimensions: 980 x 480

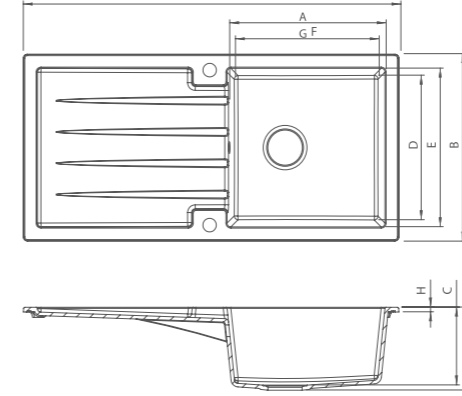

A	B	C	D	E	F	G	H	W
980	480	200	370	406	373	406	12	212

**VELLO**  
Dimensions: 780 x 500

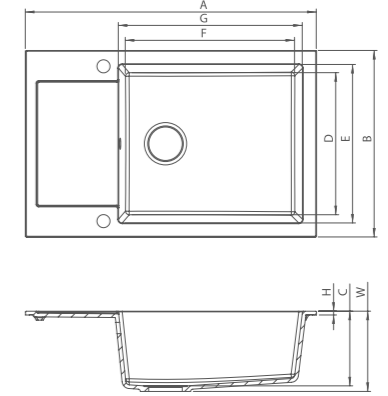

A	B	C	D	E	F	G	H	W
780	500	200	381	425	454	493	10	215

**POLLICA**

Dimensions: 780 x 480

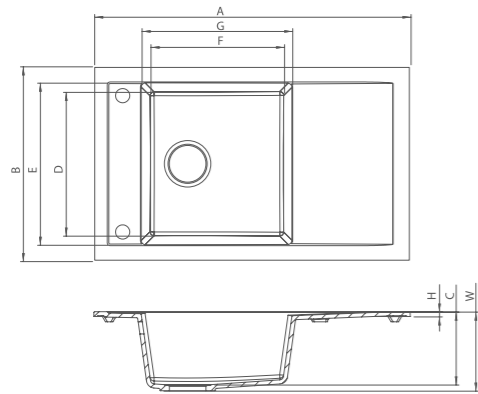

A	B	C	D	E	F	G	H	W
780	480	180	354	400	329	371	12	195

**SPEZIA**

Dimensions: 970 x 500

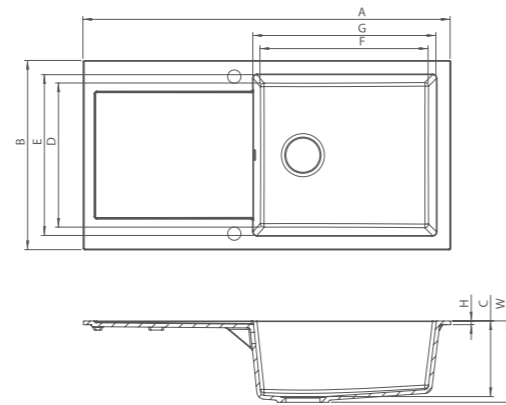

A	B	C	D	E	F	G	H	W
970	500	200	381	425	444	484	10	215

**URBINO**

Dimensions: 780 x 480

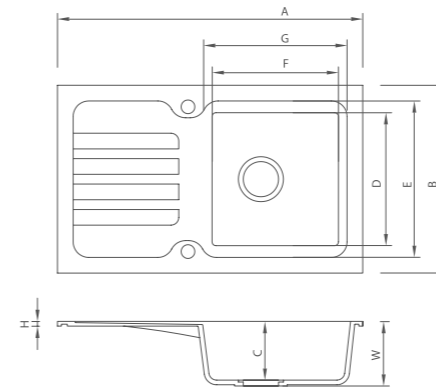

A	B	C	D	E	F	G	H	W
780	480	150	340	400	323	367	12	165

**MONTE**

Dimensions: 860 x 500

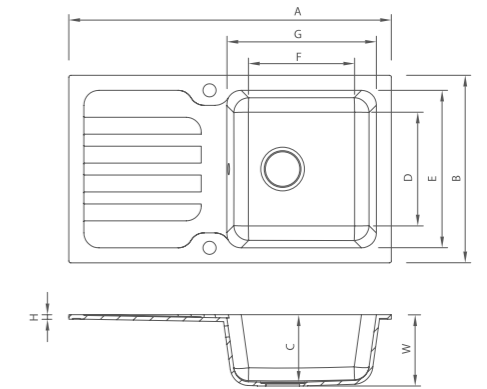

A	B	C	D	E	F	G	H	W
860	500	180	303	420	283	398	12	190

**ALBRO**

Dimensions: 1140 x 575

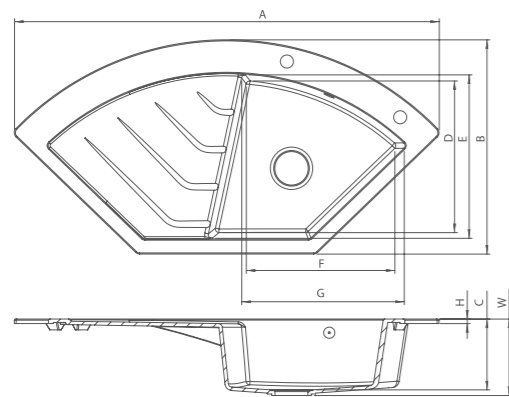

A	B	C	D	E	F	G	H	W
1140	575	190	407	439	399	436	12	205

**ERCOLE**

Dimensions: 595 x 475

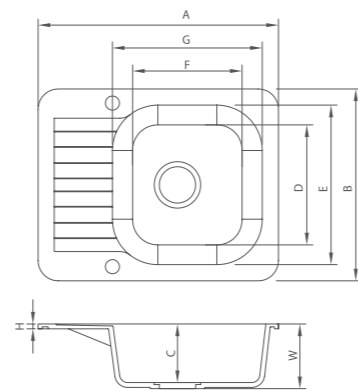

A	B	C	D	E	F	G	H	W
595	475	150	325	395	310	365	12	165

**ROSETO**

Dimensions: 1017 x 512

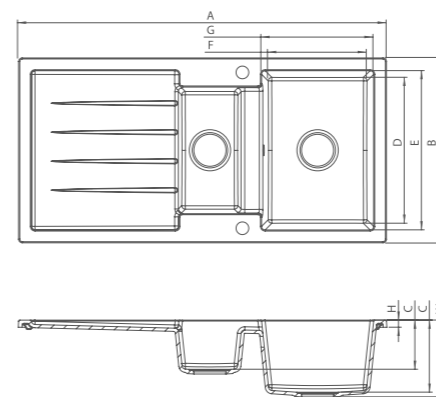

A	B	C	D	E	F	G	H	W
1017	512	136/199	403	439	273	309	20	212

**ATRANI**

Dimensions: 960 x 480

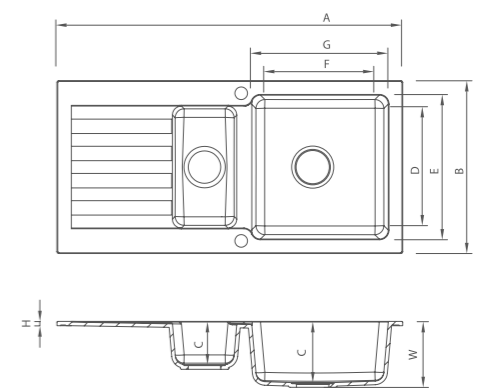

A	B	C	D	E	F	G	H	W
960	480	120/170	325	404	306	380	12	183

**LIDO**

Dimensions: 780 x 435

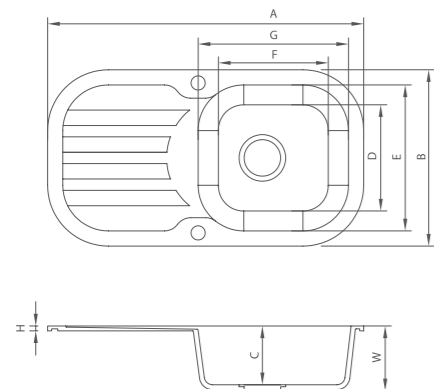

A	B	C	D	E	F	G	H	W
780	435	145	262	360	271	371	12	160

**AROLA**

Dimensions: 780 x 440

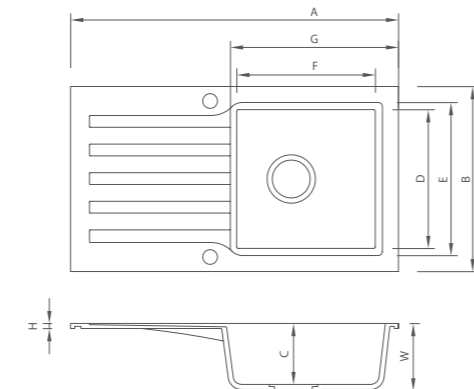

A	B	C	D	E	F	G	H	W
780	440	145	330	365	330	400	12	160

**OTRANTO**

Dimensions: 900 x 500

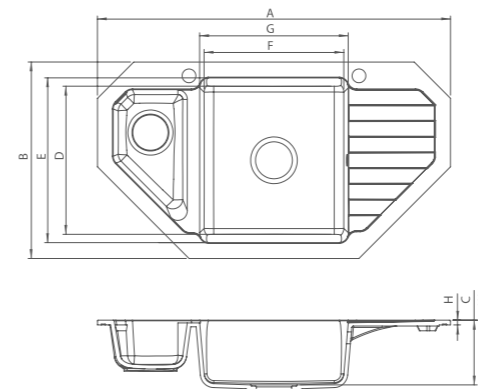

A	B	C	D	E	F	G	H	W
900	500	165	377	420	356	379	12	180

**RINELLA**

Dimensions: 800 x 500

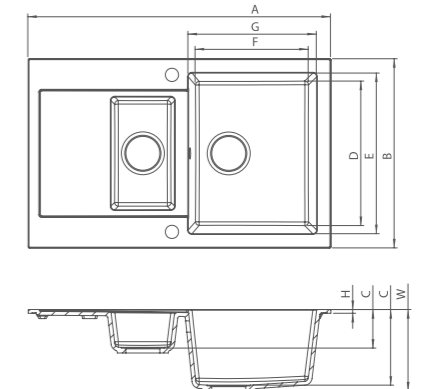

A	B	C	D	E	F	G	H	W
800	500	102/200	382	425	299	339	10	215

**TREZZA**

Dimensions: 870 x 500

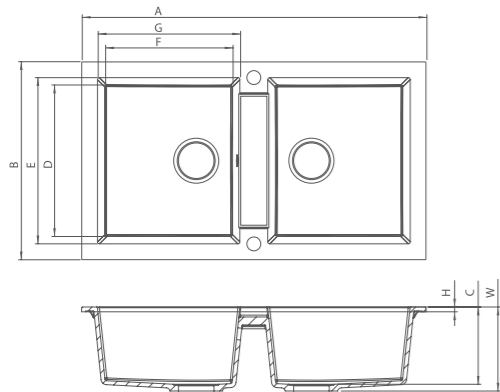

A	B	C	D	E	F	G	H	W
870	500	195	382	420	322	360	12	212

**LONGA**

Dimensions: 780 x 475

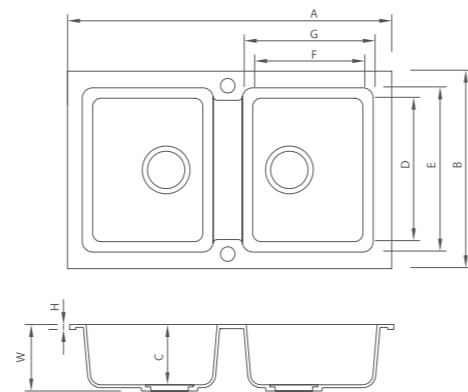

A	B	C	D	E	F	G	H	W
780	475	145	345	395	265	315	12	160

**NEMI**

Dimensions: 540 x 460

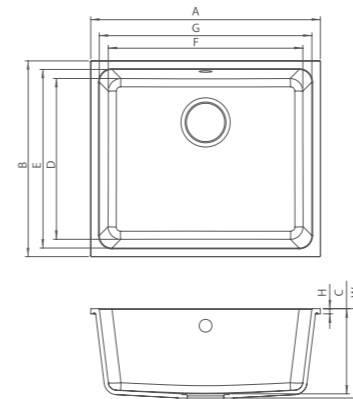

A	B	C	D	E	F	G	H	W
540	460	200	378	420	457	500	12	210

**TERRE**

Dimensions: 540 x 440

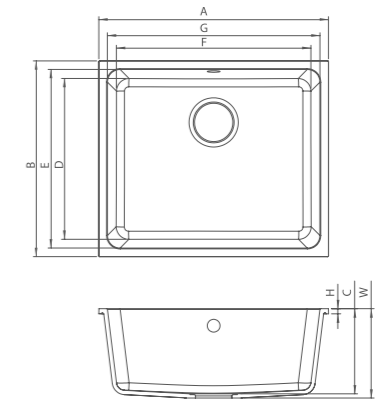

A	B	C	D	E	F	G	H	W
540	440	200	358	400	457	500	12	210

**ISOLA**

Dimensions: 610 x 465

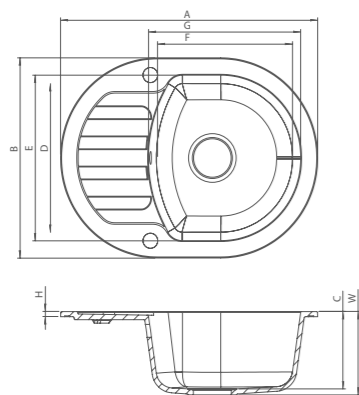

A	B	C	D	E	F	G	H	W
610	465	180	345	385	320	361	12	194

**LINGANO**

Dimensions: 500 x 500

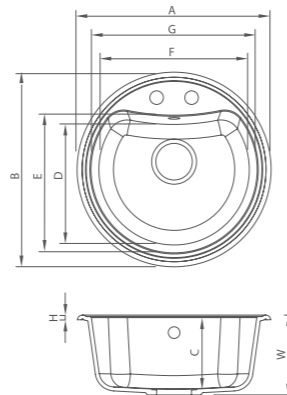

A	B	C	D	E	F	G	H	W
500	500	190	310	351	310	351	12	205

**MINTUMO**

Dimensions: 367 x 460

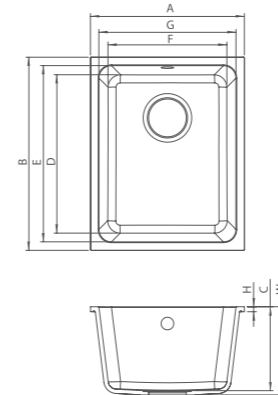

A	B	C	D	E	F	G	H	W
327	460	200	377	420	283	327	12	210

**CASTEL**

Dimensions: 510 x 510

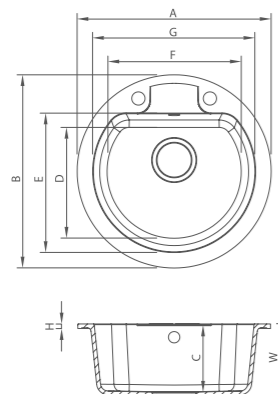

A	B	C	D	E	F	G	H	W
510	510	180	293	368	351	427	12	195

**PROCIDA**

Dimensions: 558 x 460

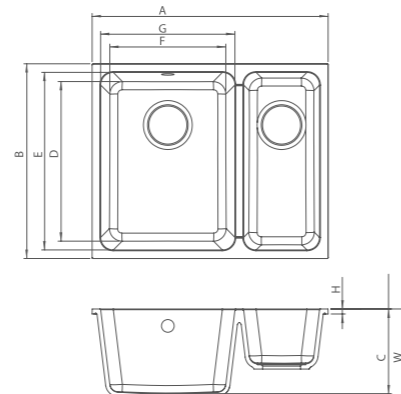

A	B	C	D	E	F	G	H	W
558	460	200	377	420	274	317	12	210

**B2B**  
PRODUCT  
DESIGN  
CENTER

# KITCHEN QUARTZ SINKS



Business to Business. Since 1985

PPHU CENTRUM sp. z o.o.  
ul. Batorego 81  
33-300 Nowy Sącz, Poland  
tel.: +48 18 444 44 35  
fax: +48 18 444 44 24  
e-mail: [biuro@pphucentrum.pl](mailto:biuro@pphucentrum.pl)  
[www.pphucentrum.pl](http://www.pphucentrum.pl)

Distribution:

